

INSTALLATION INSTRUCTIONS

FOR TREMOLO BRIDGES 2400-W4, 2405F-N5
 (FORWARD SADDLE INTONATING ONLY)



X: LOCATION OF (2) FRONT MOUNTING HOLES (USE CENTERLINE OF FRETBOARD).
SCALE LENGTH MEASUREMENT FOR CORRECT INTONATION IS FROM CRITICAL CONTACT POINT (CCP) AT NUT AND TO THE CENTER OF SADDLE TRAVEL (CST).

Y: LOCATION OF (2) REAR MOUNTING HOLES (USE CENTERLINE OF FRETBOARD)
ALIGNMENT LEFT & RIGHT FOR CORRECT STRING LOCATION ON FRETBOARD. (NOTE: L-R SADDLE ADJUSTMENTS ON BRIDGE).

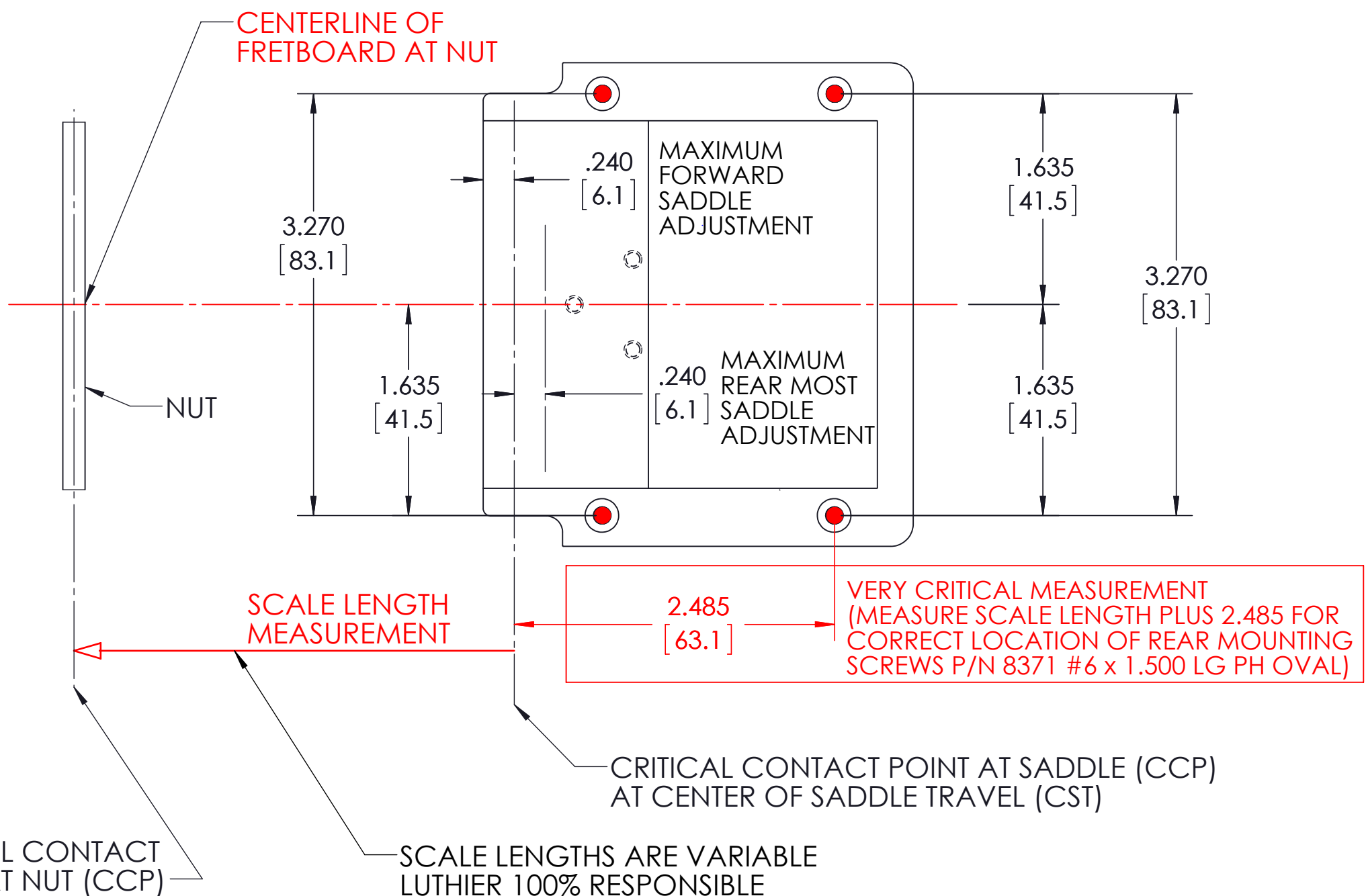
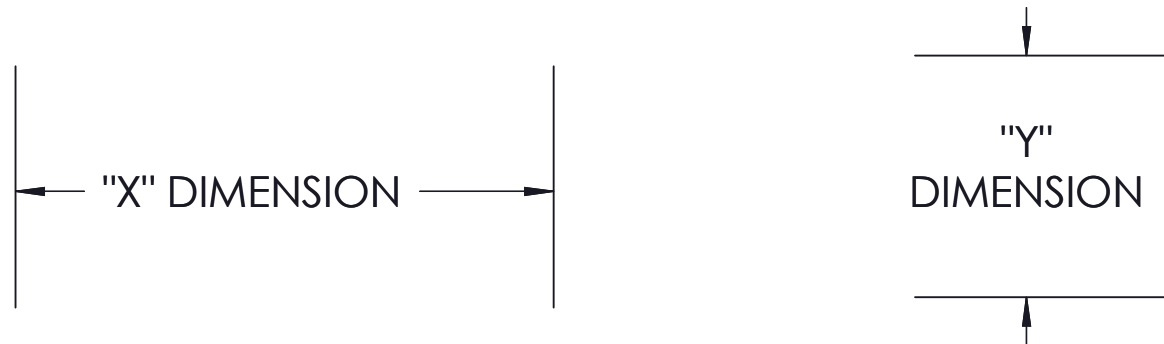

DWG is to offer assistance to a qualified Luthier. We do not guarantee 100% satisfaction on this DWG, therefore the Luthier is 100% responsible for the measurements and routings. "A GUIDE ONLY"	KAHLER INTERNATIONAL INC.		
	LOCATION MEASUREMENTS ASSY: 2400F-W4, 2405F-N5		
	DWG. NO. 6214RIMA		
	DRAWN: TASC	DATE: 03/21/11	SCALE: 1:1

LOCATION FOR ROUTING SHAPE AND DEPTH FOR
CORRECT CAM AND SPRING ACTION

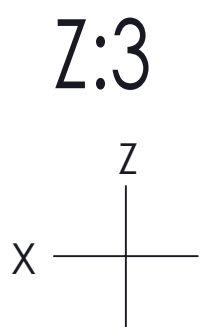
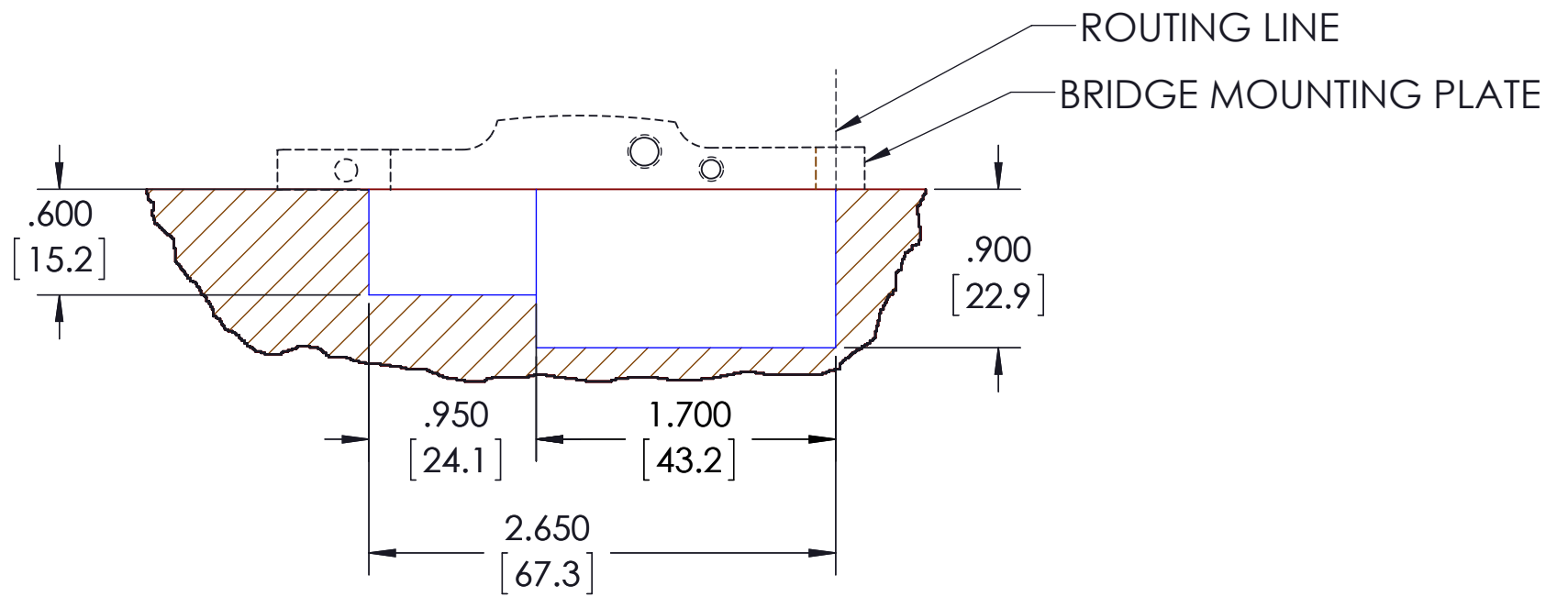
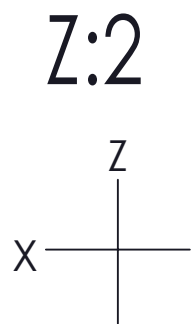
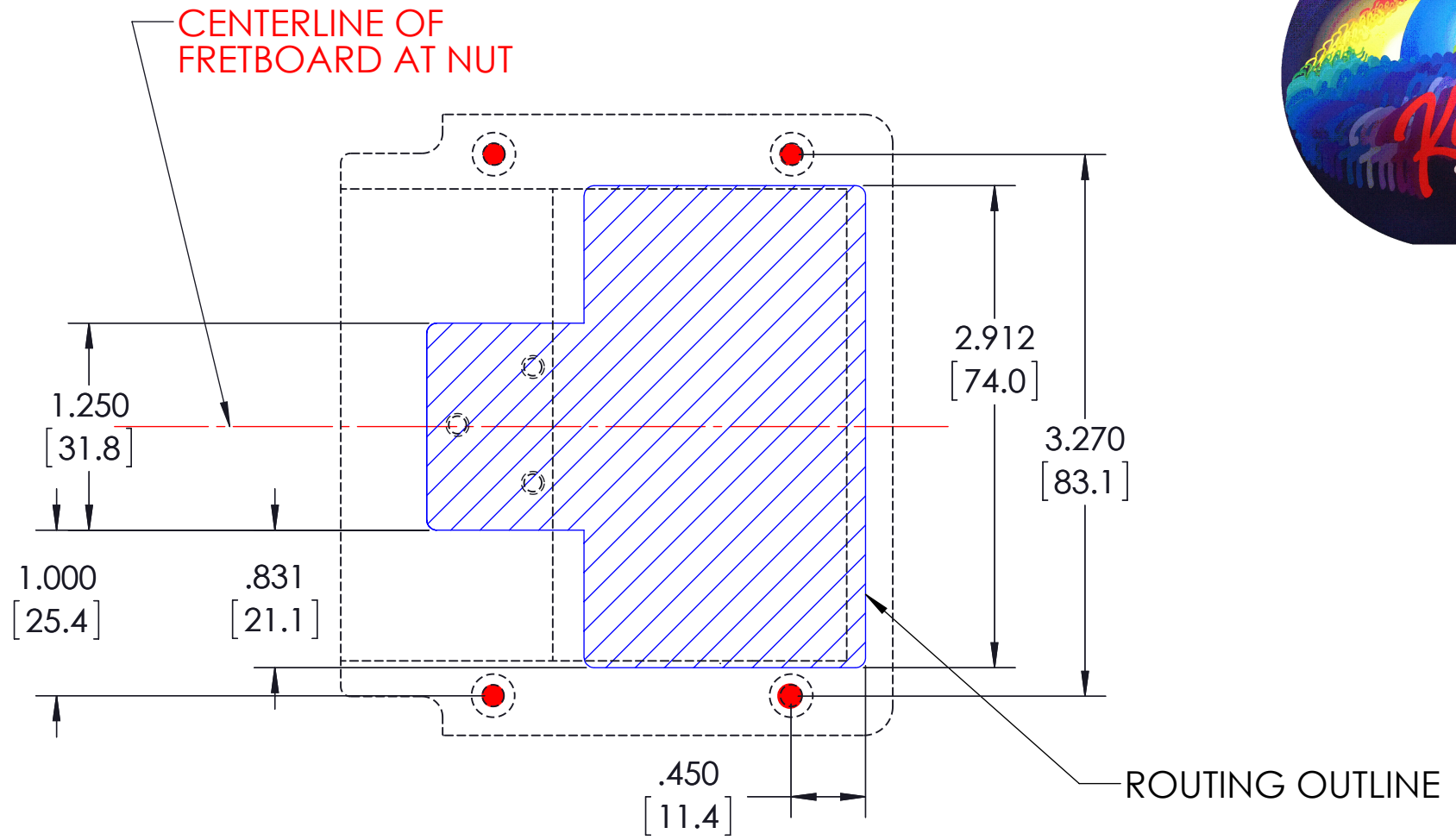
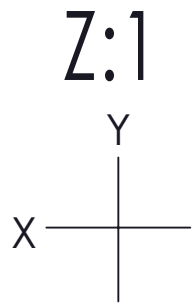
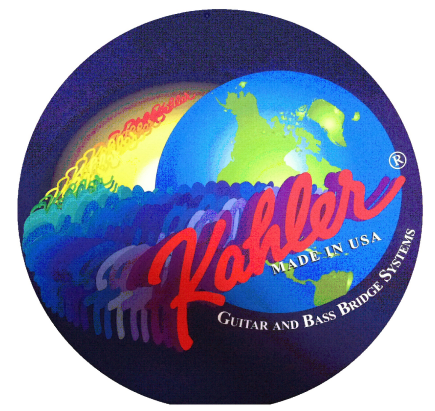

BRIDGE MOUNTING PLATE LOCATION AND
 HEIGHT MEASUREMENT FOR **CORRECT STRING ACTION**

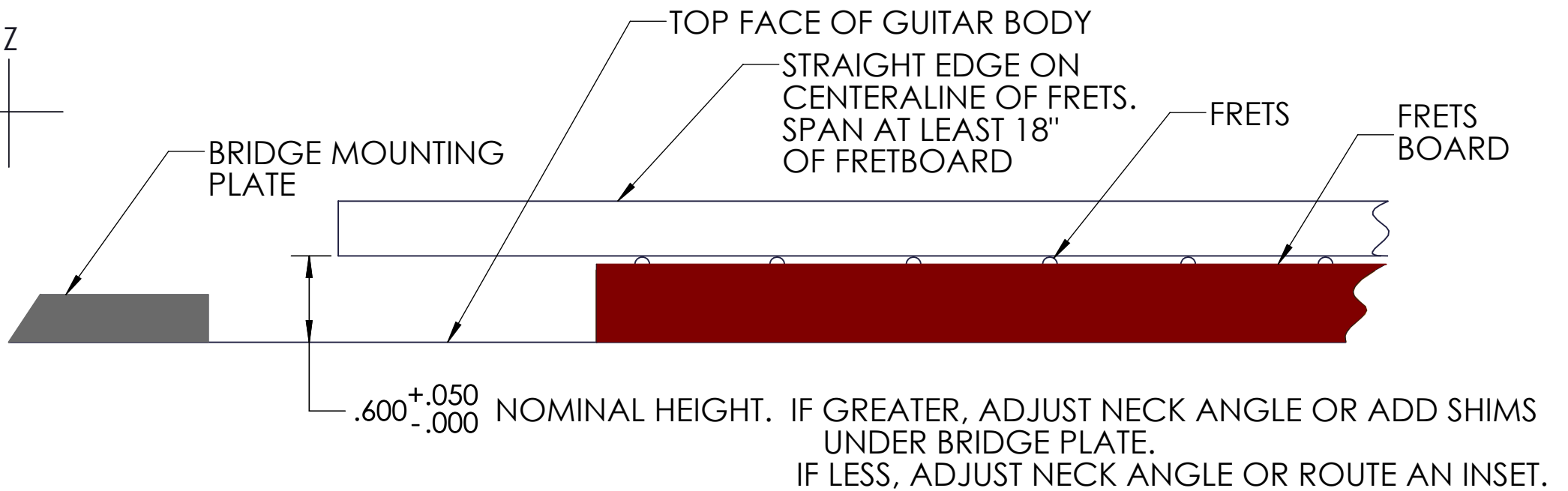

DWG is to offer assistance to a qualified Luthier. We do not guarantee 100% satisfaction on this DWG, therefore the Luthier is 100% responsible for the measurements and routings. "A GUIDE ONLY"	KAHLER INTERNATIONAL INC.		
	LOCATION MEASUREMENTS ASSY: 2400F-W4, 2405F-N5		
	DWG. NO. 6214RIMA		
	DRAWN: TASC	DATE: 03/21/11	SCALE: 1:1